

Oil Level Regulators for Lubricators

LR500 Series

The LR500 Series Level Regulators automatically add oil to a lubricator to maintain the factory-recommended level. This function eliminates the work time necessary for manual checks and refills.

Each model has a low-level shut-down switch to protect equipment when oil supply is lost. If the lubricator oil level drops below the minimum operations level, the low-level switch will operate an alarm and/or shut down the equipment.

Model LR579 is for Lincoln lubricators. It features an adjustable low-level shut-down contact.

LR589 is for Lincoln lubricators, and the LR589NC is the normally closed-wired version of the LR589.

Model LR579

Regulates Lincoln Lubricators



Dimensions

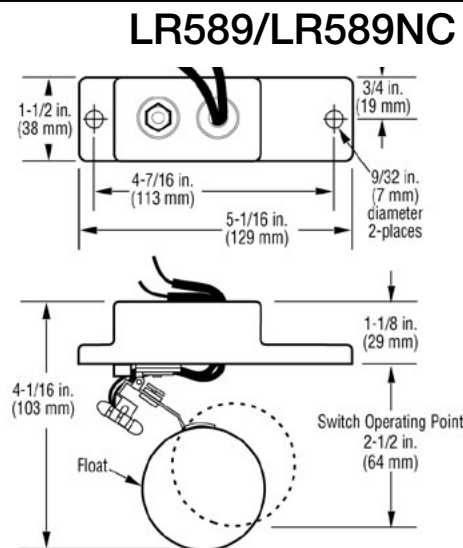
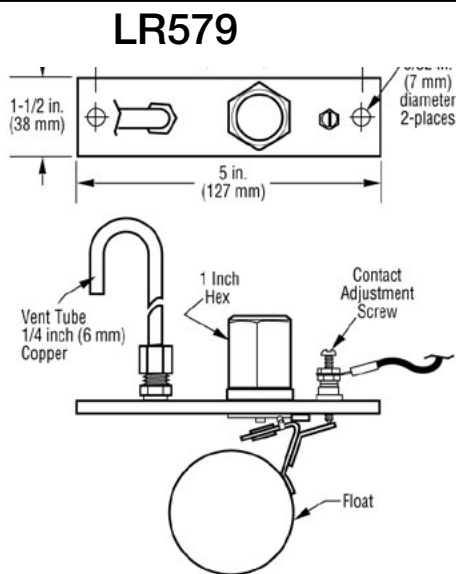

Shipping Weight and Dimensions

Shipping Weight: 13 oz. (368 g)
Shipping Dimensions: 4-3/4 x 4-3/4 x 3-1/4 in.
(121 x 121 x 83 mm)

Shipping Weight: 12 oz. (340 g)
Shipping Dimensions: 4-3/4 x 4-3/4 x 2-3/4 in.
(121 x 121 x 70 mm)

Installation



WARNING!

Before beginning installation of this Murphy product:

- Disconnect ALL electrical power to the machine.
- Make sure the machine CANNOT operate during installation.
- Follow all safety warnings of the machine manufacturer.
- Read and follow all installation instructions.

1. Remove the cover on a vacant cell of the lubricator (DO NOT install in bays next to crank arm).
2. Bolt the level regulator in place using the bolts that held the cover.
3. Connect the flex hose from the oil reservoir to the oil inlet at the level regulator. Oil reservoir must be at least two feet (0.61 meters) above the level regulator.
4. Wire switch for alarm and/or shutdown. One switch can be used to shut down all equipment supplied by a common oil reservoir.

Typical Wiring for LR579

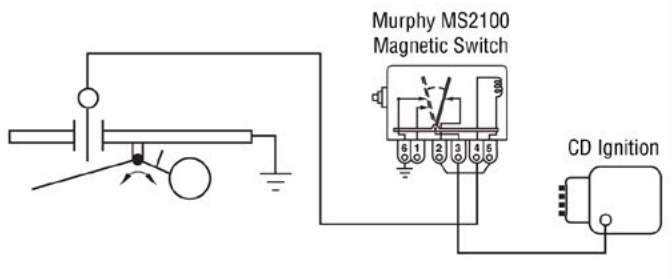

Typical Wiring for LR589

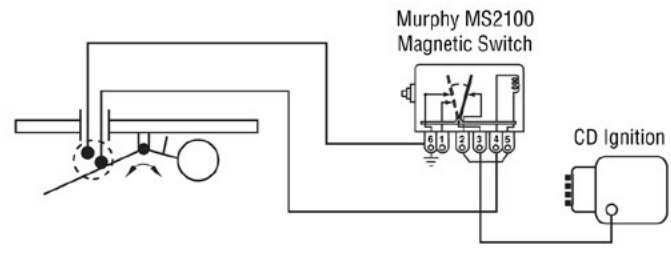

How to Order

Part Number	Model and Description	Notes
Specify Model When Ordering	LR579	
	LR589	
	LR589NC	